

MA2T

series



Product Segments

• Industrial Motion

TiMOTION's MA2T series electric linear actuator was specifically designed to endure harsh working conditions. The MA2T is an ideal solution for agricultural, industrial and commercial applications.

Embedded with an intelligent TiMOTION driver board, the MA2T can be easily integrated with different control interfaces without the need of an external control box, reducing the complexity of control and facilitating smarter operation.

The MA2T is available in three **T-Smart** alternatives:

1) T-Smart Advanced

The T-Smart Advanced alternative allows for synchronization of up to 8 actuators, as well as accurate position feedback through a variety of options (Hall, Hall-Pot., PWM).

2) T-Smart SAE J1939

This alternative provides seamless integration with CAN bus SAE J1939 interfaces, the standardized communication protocol commonly implemented in off-road vehicles and other industrial applications.

3) T-Smart Modbus

Modbus is a serial communication protocol predominantly used in industrial automation and process control. The T-Smart Modbus alternative can be smoothly incorporated into existing industrial systems.

All T-Smart alternatives are compatible with TiMOTION's software program **PGMA**, providing the user autonomy to adjust parameters such as speed, stroke limits, soft stop, soft start, and more. In addition, the PGMA provides real-time status monitoring, and gathers a comprehensive set of usage and performance data.

General Features

Max. load	8,000N (push); 4,000N (pull)
Max. speed at max. load	5.5mm/s
Max. speed at no load	52.5mm/s
Retracted length	≥ Stroke + 131mm
IP rating	IP69K
Stroke	25~1000mm
Output Signals	Hall sensors
Voltage	12 / 24 V DC
Operational temperature range	-40°C~+85°C
Operational temperature range	+5°C~+45°C

Drawing

Standard Dimensions
(mm)

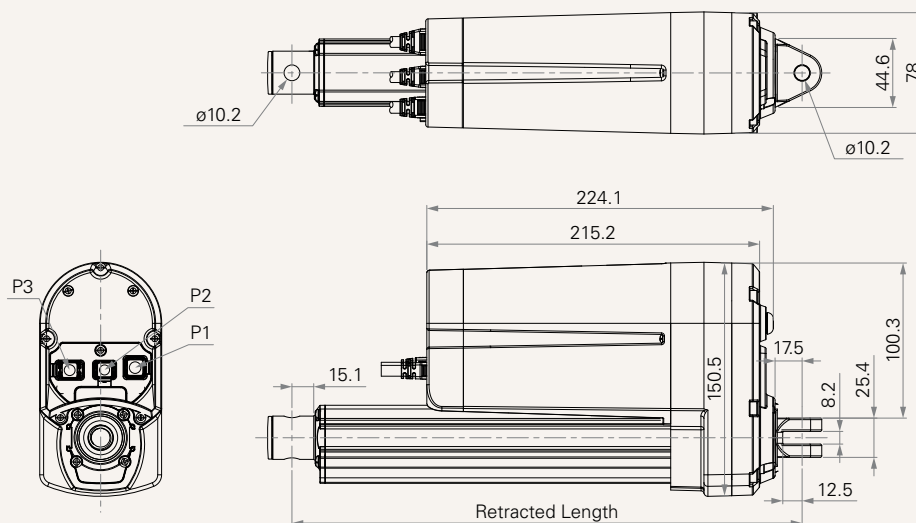

Load and Speed

CODE	Load (N)		Self Lock (N) Motor Brake	Duty Cycle	Typical Current (A)		Typical Speed (mm/s)	
	Push	Pull			No Load 24V DC	With Load 24V DC	No Load 24V DC	With Load 24V DC
Motor Speed (5200RPM)								
F	1000	1000	1300	25%	2.7	6.8	52.5	44.2
G	2000	2000	2600	25%	2.4	6.7	25.5	21.8
H	4000	4000	5200	25%	2.3	6.9	13.2	11.0
J	6000	4000	8000	25%	2.0	5.8	6.6	5.8
K	8000	4000	8000	15%	2.0	6.9	6.6	5.5

Note

- 1 Please refer to the approved drawing for the final authentic value.
- 2 This self-locking force level is reached only when a short circuit is applied on the terminals of the motor. All the TiMOTION control boxes have this feature built-in.
- 3 The current & speed in table are tested with 24V DC motor under ambient temperature 20°C. With a 12V DC motor, the current is approximately twice the current measured in 24V DC. With a 36V DC motor, the current is approximately two-thirds the current measured in 24V DC. Speed will be similar for all the voltages.
- 4 The current & speed in table are tested when the actuator is extending under push load.
- 5 The current & speed in table and diagram are tested with a stable 24V DC power supply.
- 6 With load, noise level ≤ 78dBA (by TiMOTION test standard, ambient noise level ≤ 36dBA)
- 7 Standard stroke: Min. ≥ 25mm, Max. please refer to below table.

CODE	Load (N)	Max Stroke (mm)
F	≤ 1000	1000
G	≤ 2000	800
H, J	≤ 6000	600
K	≤ 8000	200

Performance Data (24V DC Motor)

Motor Speed (5200RPM)

Speed vs. Load

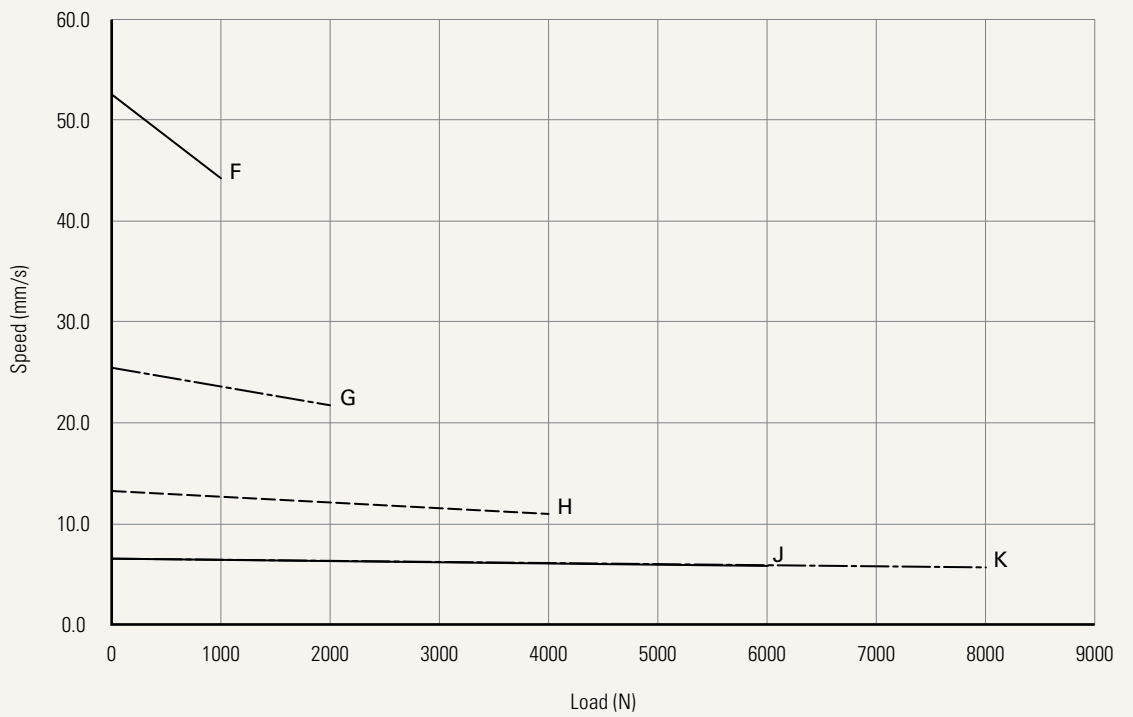

Current vs. Load

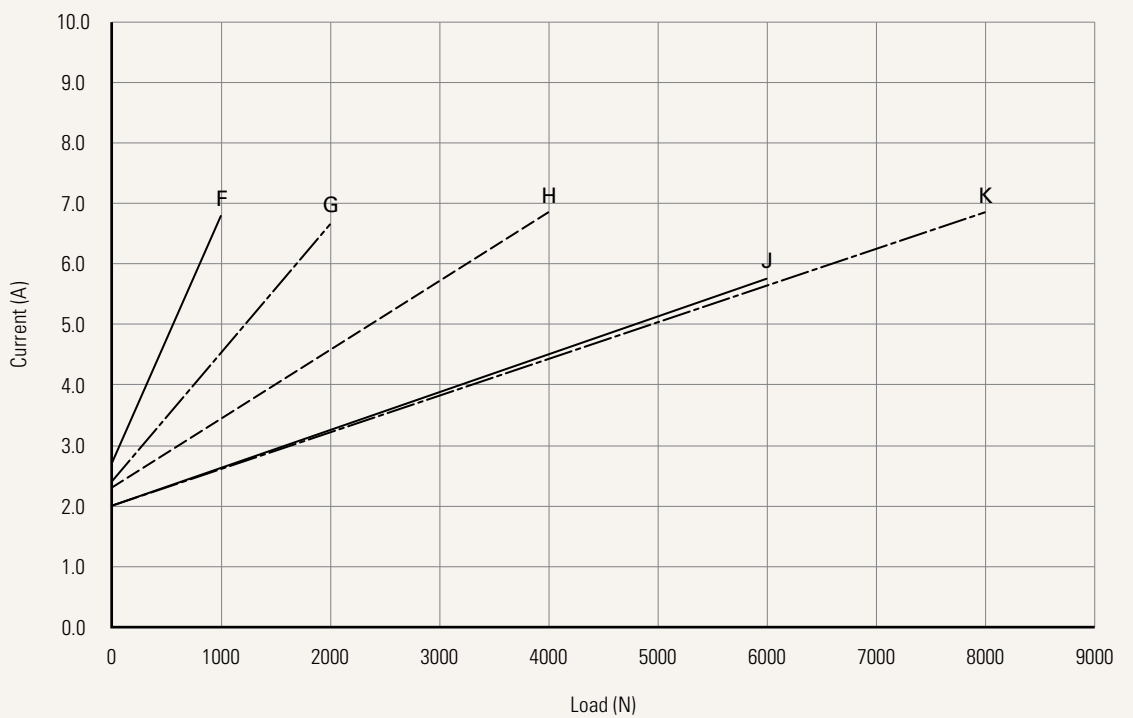

Hardware System	T = Standard driver board			
Voltage	1 = 12V DC	2 = 24V DC		
Load and Speed	See page 2			
Stroke (mm)	See page 2			
Retracted Length (mm)	See page 5			
Rear Attachment (mm)	1 = Aluminum, U clevis, slot 8.2, depth 12.5, hole 10.2 See page 5	2 = Aluminum, U clevis, slot 8.2, depth 15.0, hole 10.2	3 = Aluminum, U clevis, slot 8.2, depth 15.0, hole 12.8	4 = Aluminum, U clevis, slot 8.2, depth 15.0, hole 12.2
Front Attachment (mm)	1 = Steel inner tube with punched hole, slotless, hole 10.2 See page 6	2 = Steel inner tube with punched hole, slotless, hole 12.2	3 = Steel inner tube with punched hole, slotless, hole 12.8	4 = Aluminum, U clevis, slot 8.2, depth 15.0, hole 10.2 5 = Aluminum, U clevis, slot 8.2, depth 15.0, hole 12.2 6 = Aluminum, U clevis, slot 8.2, depth 15.0, hole 12.8 K = Rod end bearing, hole 12.8
Installation Direction (Counter-Clockwise)	1 = 0°	3 = 90°		
Functions for Limit Switches	T = Two limit switches send signal at end of stroke to T-Smart (T-Smart dedicated option)			
Adjustable Reed Switch	0 = Without			
Position Feedback	T = Hall sensor*2 for T-Smart (T-Smart dedicated option)			
IP Rating	2 = IP54	3 = IP66 (static)	6 = IP66 (dynamic)	8 = IP69K
Output Cable	3 = 3 sockets with extension cable See page 7		T = Direct cable out, 1+1 type	
P1 Connector	1 = Tinned leads See page 6			
P1 Cable Length (mm)	1000 = 1000	2000 = 2000		
P2 Connector	1 = Tinned leads See page 6	P = Dummy plug		
P2 Cable Length (mm)	0000 = Without	1000 = 1000	2000 = 2000	
P3 Connector	0 = Without See page 6	1 = Tinned leads		
P3 Cable Length (mm)	0000 = Without	1000 = 1000	2000 = 2000	
Bus Interface	C = CAN bus			

Retracted Length (mm)

1. Calculate $A+B = Y$
2. Retracted length needs to $\geq \text{Stroke}+Y$

A.		
Front Attach.	Rear Attach.	
	1	2, 3, 4
1, 2, 3	+131	+134
4, 5, 6	+161	+164
K	+178	+181

B.	
Stroke (mm)	Load & Speed Type (N)
	F, G, H, J, K
25~150	-
151~200	-
201~250	+10
251~300	+20
301~350	+30
351~400	+40
401~450	+50
451~500	+60
501~550	+70
551~600	+80
601~650	+90
651~700	+100
701~750	+110
751~800	+120
801~850	+130
851~900	+140
901~950	+150
951~1000	+160

Rear Attachment (mm)

1 = Aluminum, U clevis, slot 8.2, depth 12.5, hole 10.2

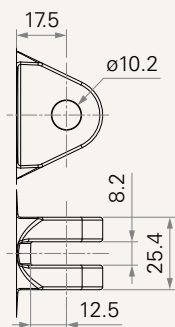

2 = Aluminum, U clevis, slot 8.2, depth 15.0, hole 10.2

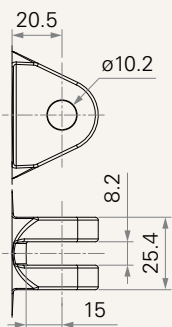

3 = Aluminum, U clevis, slot 8.2, depth 15.0, hole 12.8

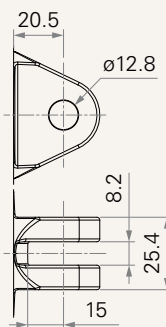

4 = Aluminum, U clevis, slot 8.2, depth 15.0, hole 12.2

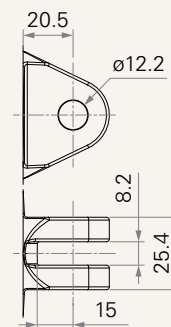

Front Attachment (mm)

1 = Steel inner tube with punched hole, slotless, hole 10.2

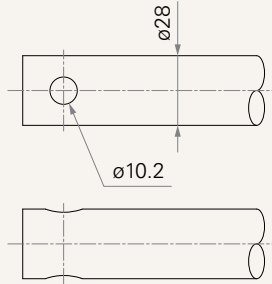

2 = Steel inner tube with punched hole, slotless, hole 12.2

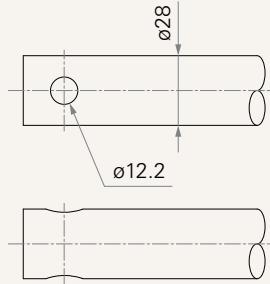

3 = Steel inner tube with punched hole, slotless, hole 12.8

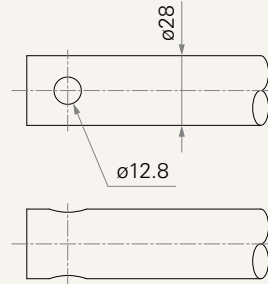

4 = Aluminum, U clevis, slot 8.2, depth 15.0, hole 10.2

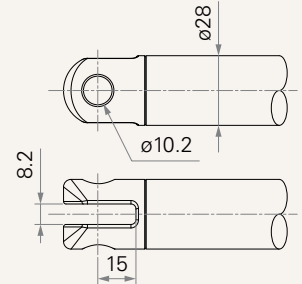

5 = Aluminum, U clevis, slot 8.2, depth 15.0, hole 12.2

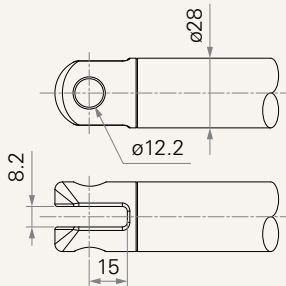

6 = Aluminum, U clevis, slot 8.2, depth 15.0, hole 12.8

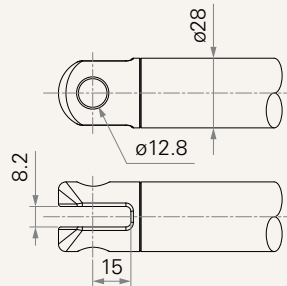

K = Rod end bearing, hole 12.8

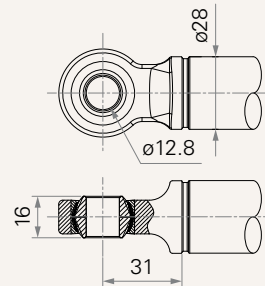

Installation Direction (Counter-Clockwise)

1 = 0°

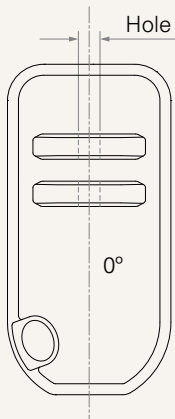

3 = 90°

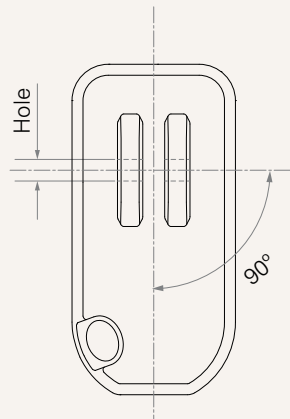

Connector

1 = Tinned lead



P = Dummy plug

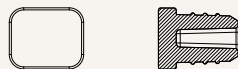

Wiring Definition

DC Vrsion With T-Smart

Port Number	Wire Color	Wire Gauge (AWG)	Position Feedback
P1	● RD	14	VDC +
	● BK	14	VDC-
P2	● RD	20	UART-+5V DC
	○ WH	20	UART-TX
	● BU	20	UART-RX
	● BK	20	UART-GND
	● BN	20	reed input 1
	● GY	20	reed input 2
	P3	● BN	20
● GY		20	Ctrl RET
● OG		20	EOS-extended
● YE		20	EOS-retracted
○ WH		20	S1/POT/CAN+
● BU		20	S2/PWM/CAN-
● RD		20	VDC +
● BK		20	Common

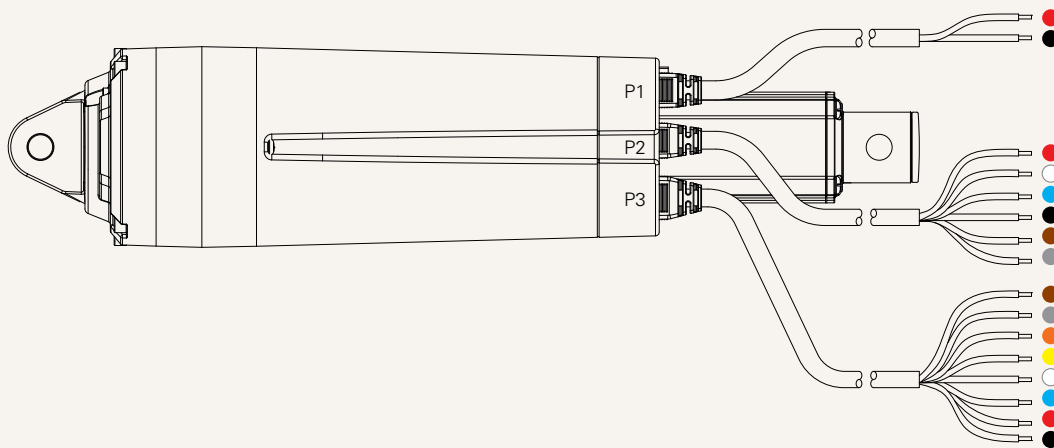

* The signal wires depend on the chosen options.

Terms of Use

The user is responsible for determining the suitability of TiMOTION products for a specific application. TiMOTION products are subject to change without prior notice.